

# OLYMPUS®

Your Vision, Our Future

Opto-digital Microscope

# DSX500

NEW

Discover another dimension

[www.olympus-ims.com/opto-digital/](http://www.olympus-ims.com/opto-digital/)



- OLYMPUS CORPORATION is ISO14001 certified.
- OLYMPUS CORPORATION is FM553994/ISO9001 certified.
- This device is designed for use in industrial environments for the EMC performance (IEC61326-1 Class A device). Using it in a residential environment may affect other equipment in the environment.
- All other company and product names are registered trademarks and/or trademarks of their respective owners.
- Images on the PC monitors are simulated.
- Specifications and appearances are subject to change without any notice or obligation on the part of the manufacturer.

OLYMPUS®

**OLYMPUS CORPORATION**  
Shinjuku Monolith, 3-1, Nishi Shinjuku 2-chome, Shinjuku-ku, Tokyo, Japan  
**OLYMPUS EUROPA HOLDING GMBH**  
Wendenstrasse 14-18, 20097 Hamburg, Germany  
**OLYMPUS AMERICA INC.**  
3500 Corporate Parkway, Center Valley, Pennsylvania 18034-0610, U.S.A.  
**OLYMPUS (CHINA) CO., LTD.**  
11F, K, Wah Centre, 1010 Huaihai Rd(M), Xuhui District, Shanghai, P.R.C.

**OLYMPUS KOREA CO., LTD.**  
Olympus-Tower, 114-9 Samseong-Dong, Gangnam-Gu, Seoul, Korea  
**OLYMPUS SINGAPORE PTE LTD.**  
491B River Valley Road, #12-01/04 Valley Point Office Tower, Singapore  
**OLYMPUS AUSTRALIA PTY. LTD.**  
31 Gilby Road, Mt. Waverley, VIC 3149, Melbourne, Australia  
**OLYMPUS LATIN AMERICA, INC.**  
5301 Blue Lagoon Drive, Suite 290 Miami, FL 33126, U.S.A.

[www.olympus-ims.com](http://www.olympus-ims.com)



When You Need to See a New Dimension,  
Olympus Provides the Answer



DSX500, the opto-digital microscope is the new standard for industrial microscopes. Born of Olympus' leading-edge opto-digital technology, this scope offers operating simplicity and a level of reliability unheard of among so-called digital microscopes. Any operator, regardless of experience, can use Olympus DSX500 to get complete inspection and accurate analysis every time.

**Superb Operating Simplicity**  **Absolute Performance Reliability**

# Opto-digital Microscope DSX500

# DSX500 Offers a New World of Observation and Analysis

## Various Observation Methods with Simple Operations. Quickly Achieve the Image Definition You Need for Observation

Can be used for any industrial microscopic observation method. Also, a new MIX observation method combines BF and DF. Where experts had to conduct observations before, now pressing a single button changes the image on screen, and you get the high-resolution images expected of high-end optical microscopes.



- BF**  
Bright-field observation. The most common method with optical microscopes.
- DF**  
Dark-field observation. Illuminate from the side to emphasize imperfections. Best method for identifying defects.
- DIC**  
Differential Interference Contrast observation. The method to use when inspecting uneven surfaces.
- PO**  
Polarized light observation. Used to inspect copper lines through a polarized filter.
- MIX(BF+DF)**  
While observing samples with the bright-field measurement method, you can detect defects and imperfections without switching back and forth between bright-field and dark-field images.



Page 08-09

## Digital Clarity Exceeds the Naked Eye, with Superb High-definition Sample Surface Images

In addition to advanced optics, use of HDR (High Dynamic Range) clearly shows hard-to-see microscopic textures as well as samples prone to halation, which were difficult to see before.

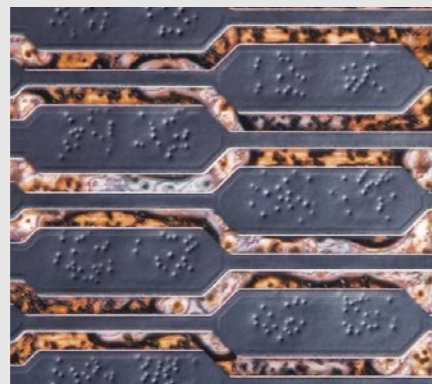

HDR



Page 08-09

## Sample Surface Shown Clearly in 3D

Sample surface can be shown in 3D from any angle. Extended focal image maintains focus across the entire sample surface.

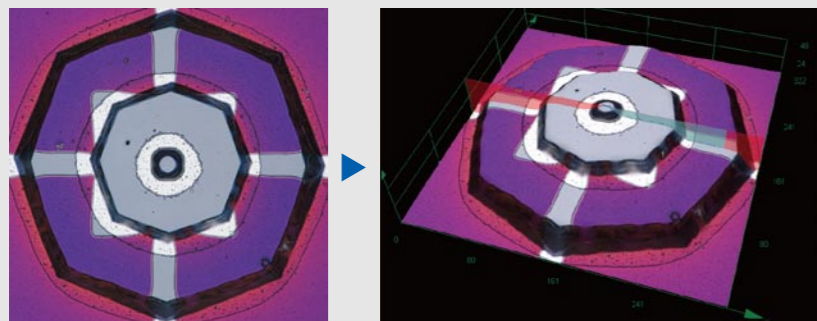

2D image with everything in focus

3D images at a touch



Page 10-11

## Panoramic Photos Include Areas beyond the Field of Vision

Panoramic photos let you easily take photos of areas beyond the field of vision, which are automatically synthesized into a screen image to show a very broad field in high definition. 2D, EFI, and 3D can all be synthesized.



Panoramic image



Page 10-11

## Standard Features Enable a Huge Variety of Measurements, So All Your Measurement Objectives Are Met

All items for 2D and 3D industrial microscope measurements are standard features, so it is easy to quantify measurement results. In addition to the standard methods of surface measurement, profile measurement, uneven surface measurement, area and volume measurement, options include both caliper measurement and profile measurement.

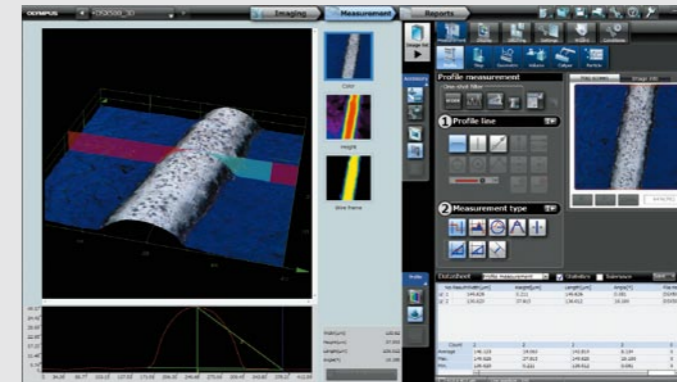

Profile measurement



Page 14-15

## Quick Simple Measurement with a Report Function

One click sets the report function in motion to record and create a report of the images and results of measurements and observations. The system can be set to follow applications and greatly improve efficiency.

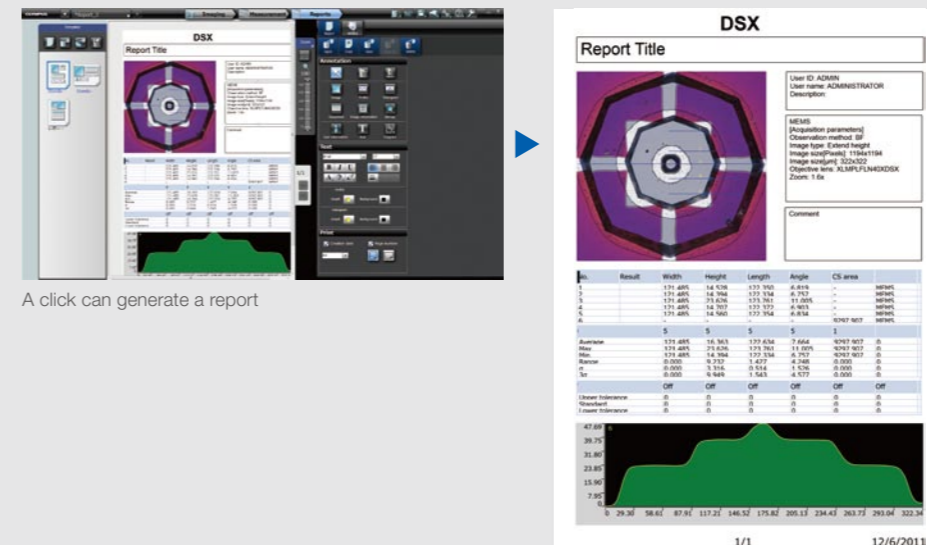

A click can generate a report

Report output



Page 11



# Operating Simplicity that Guides Operators to Optimum Output, Regardless of Their Experience

A new way to see. No peering through microscope eyepieces, because everything shows on the GUI screen. So you operate the scope with touch panel, mouse, or computer. What's more, virtually anybody can use this new operating system, whatever their experience. The screens guide the operator through the procedure, from inspection to measurement and analysis to final report. Short, simple steps. Quick results.



### Tutorial Mode

Eliminates the confusing aspects of operating a microscope. Just follow the suggestions the system gives for excellent output every time.

### Advanced Mode

Makes jobs super easy for the experienced operator. Laid out for action. Powered controls make operation much speedier.



### Operator Mode

This mode is customizable for speedy routine work. Most efficient when the same task is done repeatedly.



Three user-selectable modes — Choose your mode according to the measurement environment

### Three Modes to Set According to Operator Experience and Job Demands

Select Tutorial Mode or Advanced Mode to match the experience of the operator and the job at hand. And Advanced Mode can be customized to match operator experience or to do routine work. The operator's ID and password open the application, and it automatically sets the scope to the operator's preferred observation, analysis, or measurement settings along with the screen visual the operator normally uses.

### New User Interface Changes Thinking about Microscope Operation

Where an operator had to make complicated adjustments before, with DSX500, it's simple. Once the sample is in place, everything is controlled by computer mouse, joystick, or touch screen – inspection position, focus, zoom, illumination, and choice of several inspection and operation methods. And you can easily find the inspection position you want, just by moving the image on the touch screen with your finger until it is in the right place. What's more, pinching—enlarging by spreading two fingers, reducing by bringing two fingers together—work on the DSX500 touch screen as well. All controls are direct and easily performed. Furthermore, auto-focus/auto-gain make sure illumination of and focus on the sample are correct.



GUI enables a direct, comfortable operation

### Macro Map Always Shows Where You Are

Where conventional microscopes tend to lose focus in dark-field image, DSX500 stays in bright-field image mode even when changing observation methods. That means no confusion when increasing or reducing magnification. On the screen, a macro map shows the exact observing point. And the panoramic view function combines photos of several points into a single, larger image.



Macro map always shows where you are

### Optical Zoom Gives Close-up and Wide-angle as Needed

Change magnification as needed, even by slight degrees, with the view automatically in focus by AF function as the change is being made. A single lens gives you optics of 13x and digital zoom for a maximum of 30x. Plus, two lenses can be mounted at once for even greater magnification range. When inspecting a sample, you may want to switch lenses. When you do, DSX500 automatically adjusts lens and digital zoom to the exact same magnification level so you start anew at the very same place with the very same field of view. In addition, a specially designed long working distance lenses allow inspection and measurement of samples with uneven surfaces without worry of lens-sample contact.



# Operating Simplicity Lets Even the Inexperienced Observe Samples They Couldn't Before

The leading-edge digital technology of this microscope lets you see more than any other microscope can. Here-fore, only experts with years of experience could adjust microscopes to achieve really good views of relevant samples. But DSX500 allows any operator to do that with a GUI screen. Now all it takes is a touch of the finger to follow a few easy steps to get exact output from inspection to diagnosis to pertinent reports.

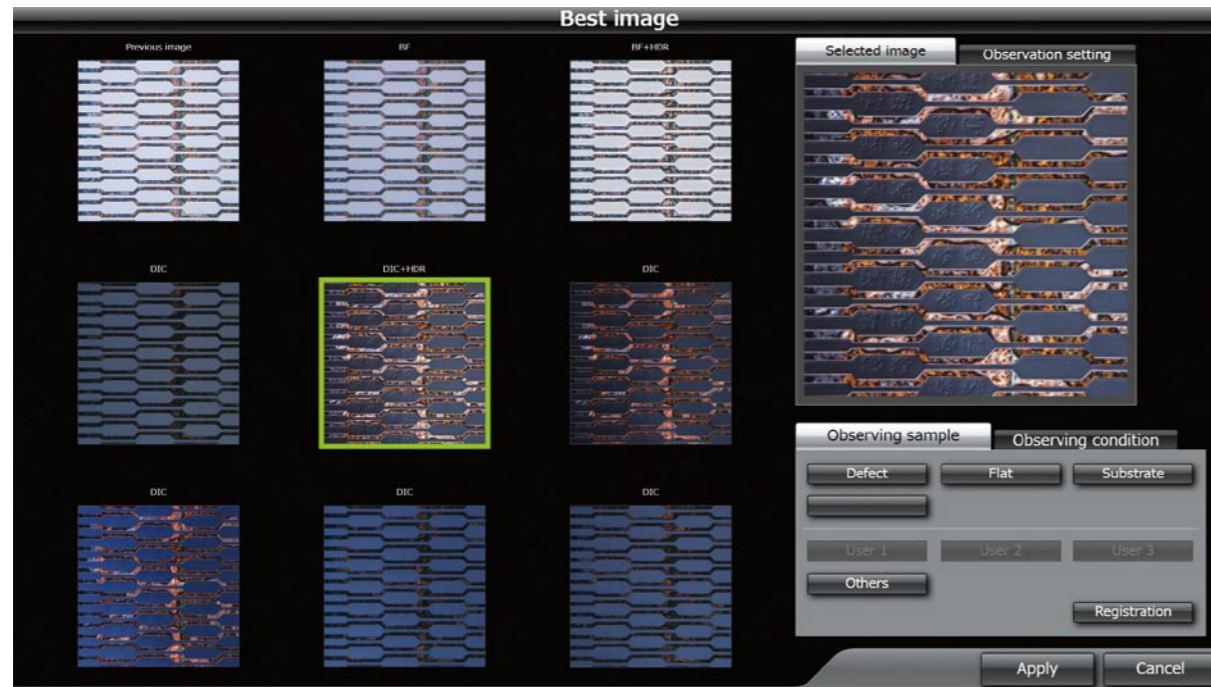

Best Image — Just choose the image you want from the previews on the screen

## Best Image Function Ensures Optimum Microscope Performance

Now you can operate your microscope just by choosing, and leave the inspection method up to the microscope. That ensures the best possible image, whether looking for defects, uneven surfaces, or foreign objects. Anyone can operate the system, beginner or expert, and it can be customized for operator or operation. Put the inspection methods in memory, and whoever operates the scope will get the same results; no scattering.

## Change Observation Methods with One Click – No Presetting Necessary

With virtually every industrial observation method at hand, it's easy to choose the proper one for the current task. Just choose the proper method with the click of a button. No complicated adjustments needed.



A click of a button gives you the image you want on screen

## HDR Gives Ultra High-Definition Visuals That Go Beyond the Human Eye

Dark-field risks blackout and bright-field risks halation, but the HDR (High Dynamic Range) function of DSX500 scopes synthesizes several images taken at different exposures to eliminate such problems. HDR promises high-fidelity images in which textures stand out and there is no halation, so defects that were undetectable now stand out.

## MIX Observation Method Easily Detects Defects and Imperfections

MIX combines bright-field (BF) measurement with dark-field (DF) LED illumination, something conventional microscopes cannot. With bright-field visibility and added dark-field detection capabilities, defects and imperfections can be detected while observing the sample.

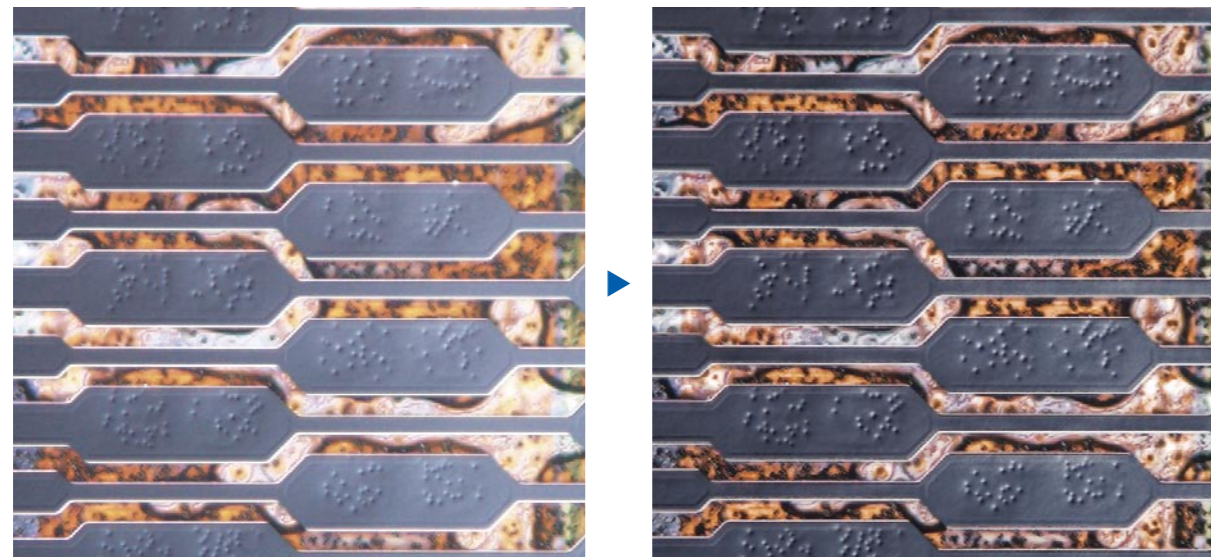

HDR — enables ultra high-definition inspection in dark-field and DIC images with one click

## WiDER Provides Easy Inspection of Samples with High Luminance Difference

If the shadowed areas black out, merely upping the illumination power is often not enough, because then halation occurs. Olympus intelligent image processing technology eliminates these problems with WiDER, a proprietary system ready to go at the click of a button. It takes care of the high contrast problems without reducing the frame rate. No blackouts. No halation.

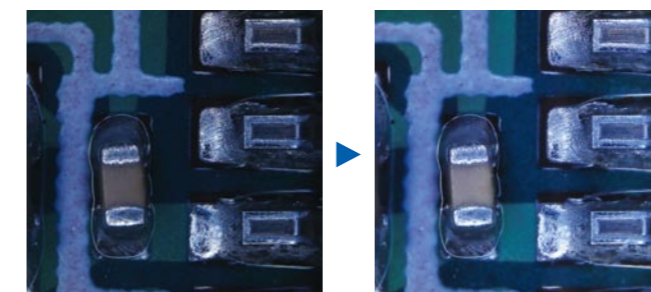

When high contrast problems occur, a click lets you see everything in real time

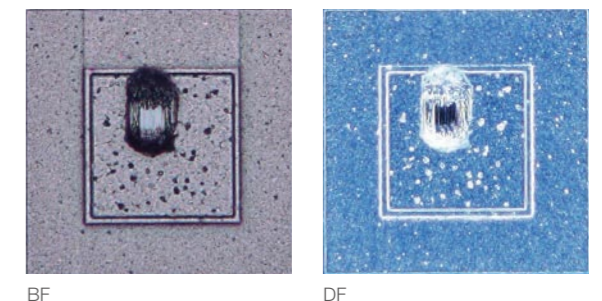

MIX(BF+DF)



# A Simple Operation Lets You See Now What You Couldn't See Before

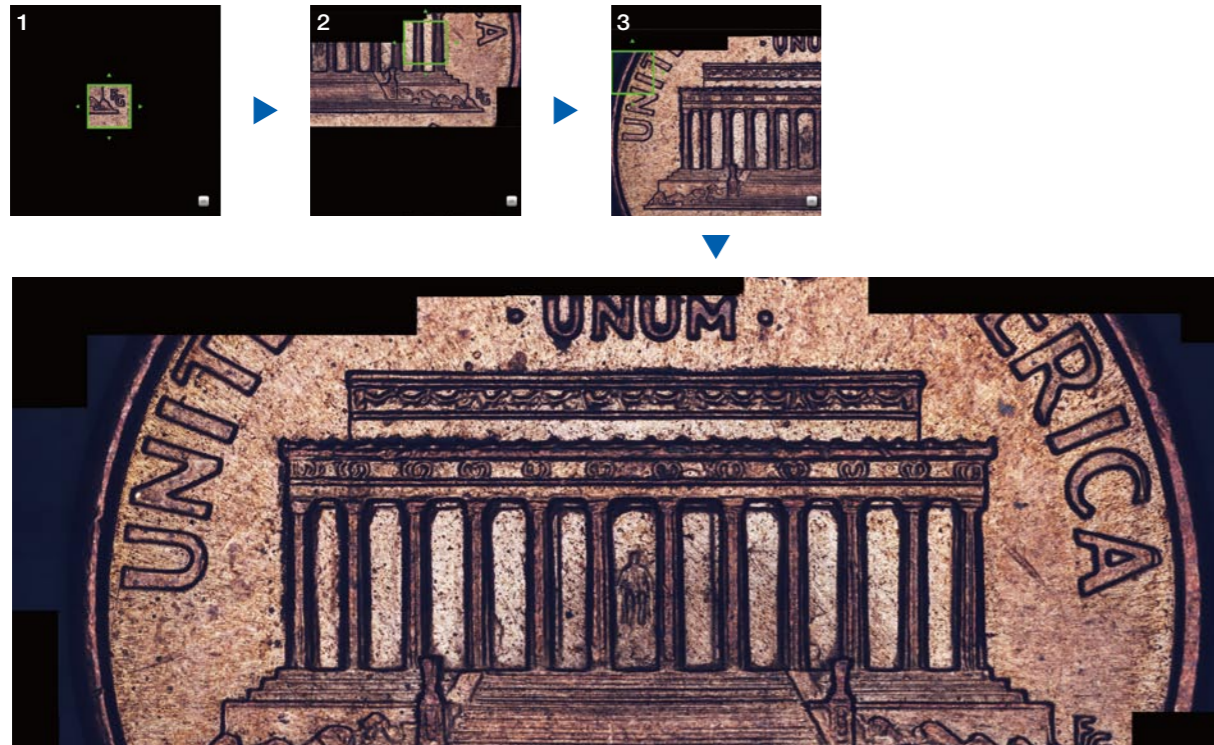

Panoramic photos — Use the mouse or your finger to select what you want in the view, and it's all linked together on screen

The DSX500 requires no extensive knowledge or special techniques to show you exactly what you want to see. By calling on leading-edge electronic technology, you can now see what was unclear or impossible before. Of course, there are no difficult processes either. Just press the buttons on the menu to see what you want.

## Panoramic Photos Include Areas beyond the Field of Vision

No such thing as “outside the field of vision.” Just move the observation position on the screen, and the motorized stage will move the sample to that place. As the stage moves, the system automatically stitches images into a single large field of view, in real time. Where conventional microscopes reduce field area with increases in magnification, Panoramic View maintains the original field while giving close-up clarity – with 2D, expanded focus, or 3D, or any combination of one or all.

## 3D Photo Feature Shows the Sample as It Actually Is

Inspect or observe the sample as it is, because DSX500 can easily show it in three dimensions, and you can examine it from any angle.

## EFI Capabilities Show Everything

Where conventional microscopes can focus only at one place, DSX500 Extend Focal Image (EFI) maintains focus across the entire target surface area. This makes uneven surfaces easy to inspect.

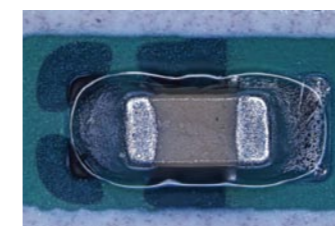
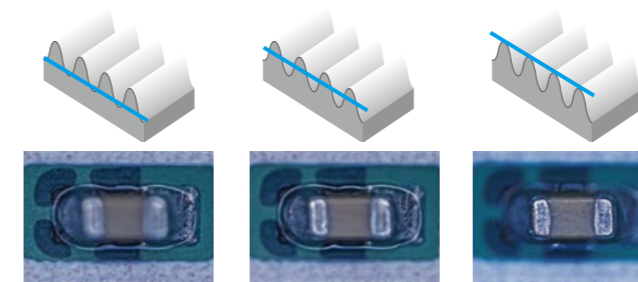

Even when using dark-field or DIC images, focus is automatically maintained across the field of view

## The Report Function Gathers the Results Together Efficiently

With DSX500, you can do observation or measurement, and the operator's workflow includes preparation of relevant reports that can be output in rich text (rtf), or PDF formats.

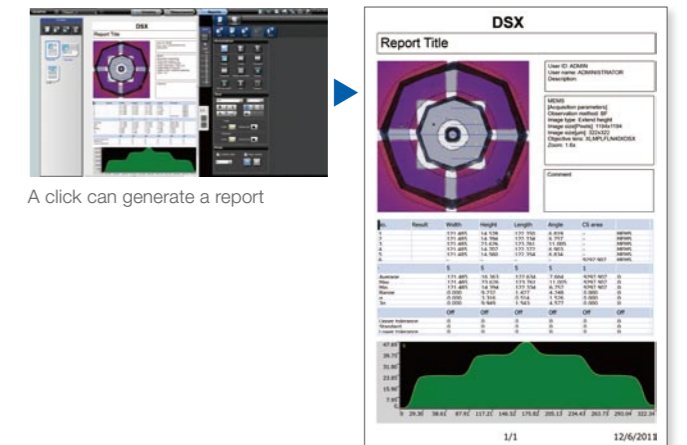

A click can generate a report

Report output

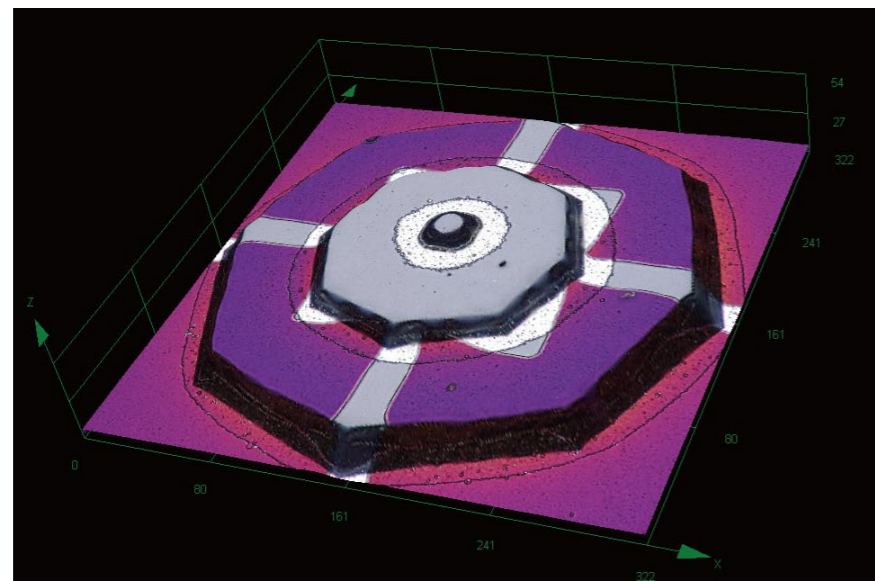

3D measurement — The click of a button turns the visual into 3D

## Color Enhancement Feature Shows Only What You Want to See

If you put what you need to see in color and leave the rest in monotone, it's much easier to find defects, if any exist. And you can photograph just that part, too, which makes reports even more effective.

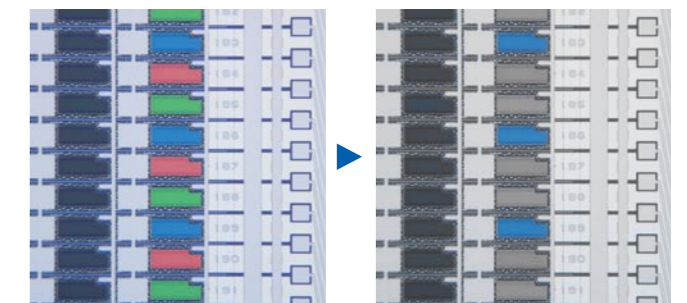

Inspection is easier when you can highlight possible defects or contamination for inspection



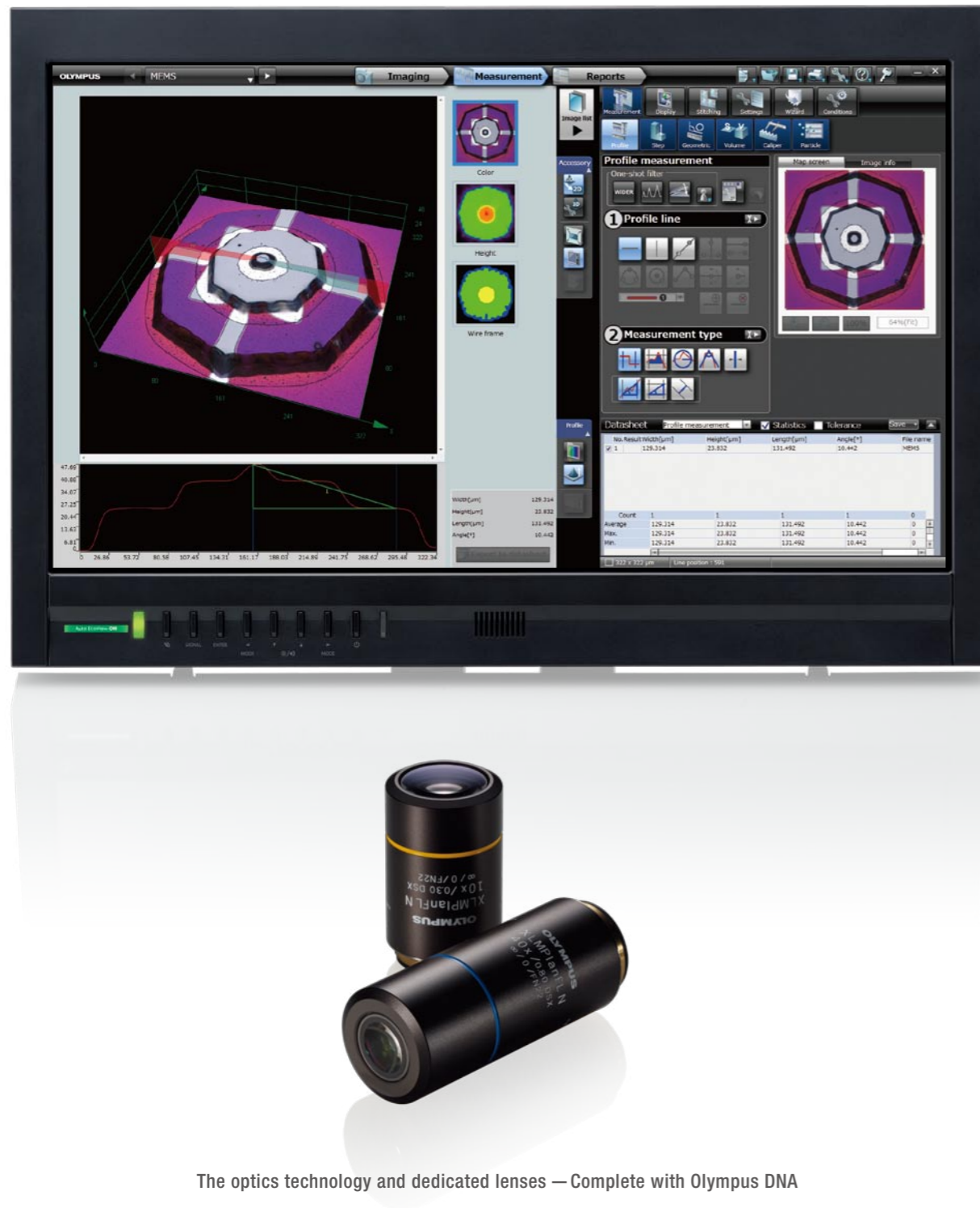

The optics technology and dedicated lenses — Complete with Olympus DNA

## DNA from Olympus Gives DSX Microscopes the Ability to See What Digital Microscopes Cannot

Olympus guarantees the reliability of all DSX500 microscopes because they are born of Olympus optics and opto-digital technology. Halation is minimal and color reproduction is real. And to make sure of that, Olympus uses the perfect combination of CCD chips and graphic boards. The sample is reproduced with such accuracy it's like a new dimension.

### Ultra High-Quality Optics Let You See Into Another Dimension

Olympus DNA includes superior engineering and design capabilities as well as proven manufacturing quality. In the clear images produced by the DSX500 opto-digital microscope, you'll find neither flare nor distortion. That's something no digital microscope can claim.

### 18MP Images Reproduced in very High Resolution with High-Performance CCD\*

As the engine that shows exactly what the high-quality optics reveal, exceptionally high-performance CCD reproduces the colors precisely. The image shift function ensures very high fidelity with fine detail processing of images, so the detail clarity extends from corner to corner.

\*4800x3600 pixels, 3CCD mode conversion triples the pixel count

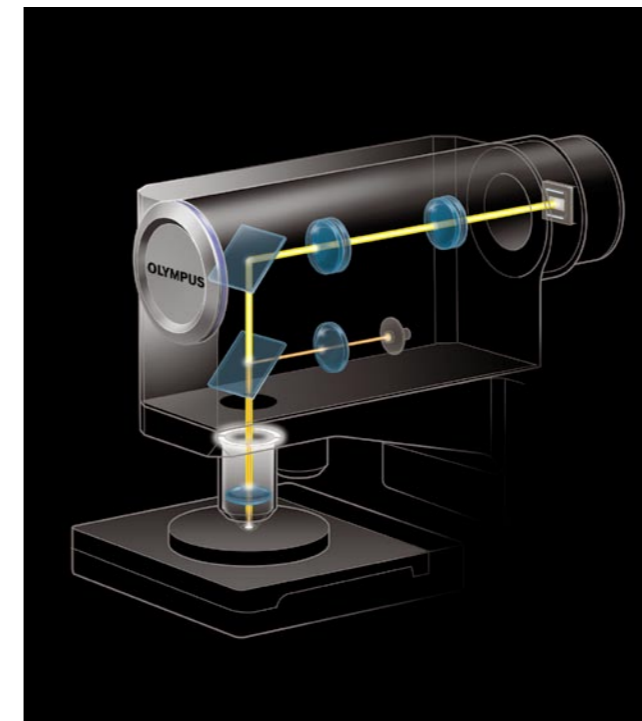

The optics technology and dedicated lenses — complete with Olympus DNA

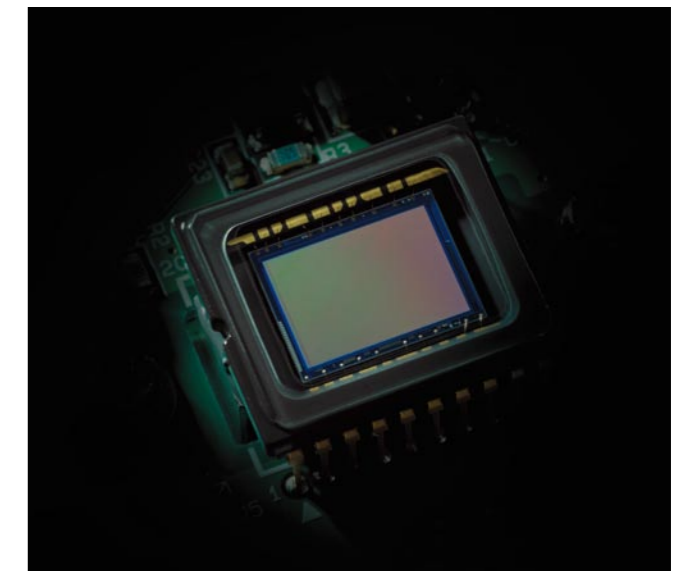

High-performance CCD

### LED Illumination Gives Picture-Perfect Inspection with Much Less Energy

New LED illumination not only assures accurate observation, but also achieves both energy conservation and lower running costs. What's more, the light color temperature does not change with intensity. And the long working life of the elements means the scopes are virtually maintenance free.

### Dedicated DSX500 Field Lenses Make High-Grade Image Dissection a Simple Matter

These new lenses were especially designed and manufactured for DSX500 10x and 40x scopes. And they put high NA and long working distance together. Just zoom in electronically, and suddenly you've got extremely high resolution. On samples with very rough surfaces, high-resolution observation is simple and reliable. What's more, you can use UIS2 lenses, which provide high resolution and contrast.



# Precision Measurement with Absolute Reliability that Cannot Be Matched by Conventional Digital Microscopes

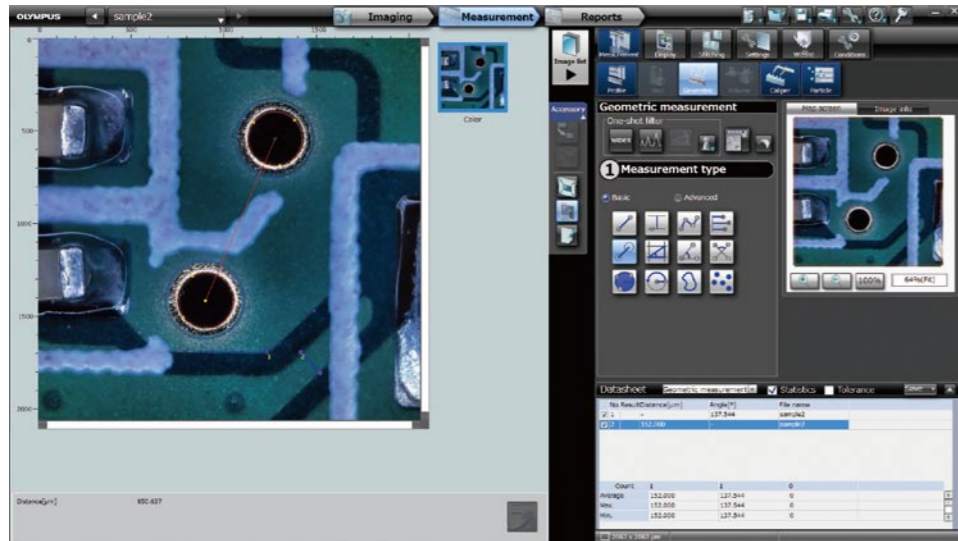

Mechanized 2D measurement

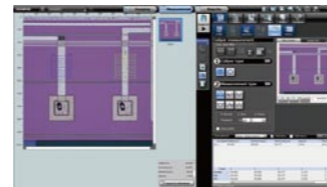

Caliper measurement

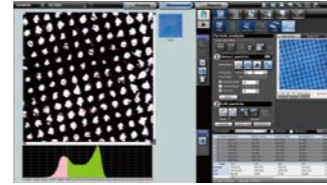

Particle analysis

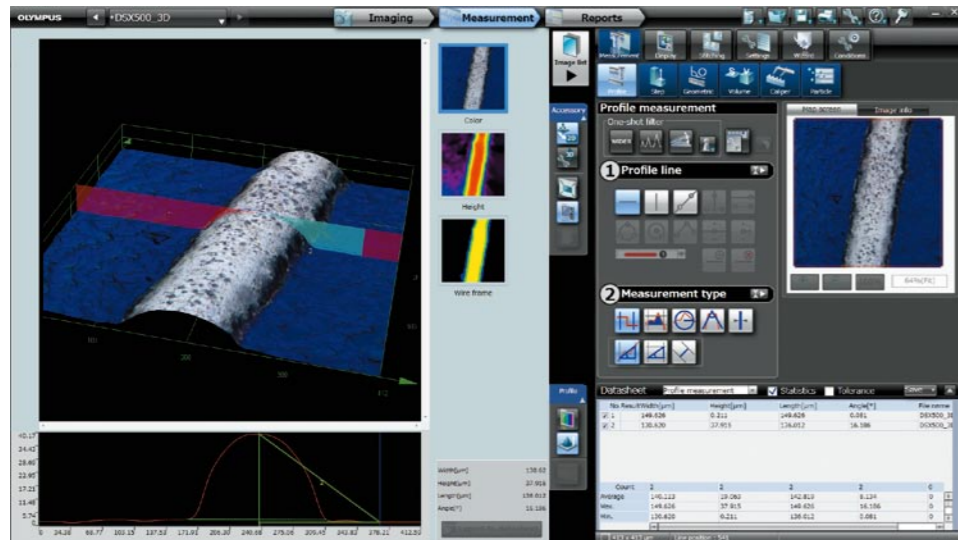

Profile 3D measurement

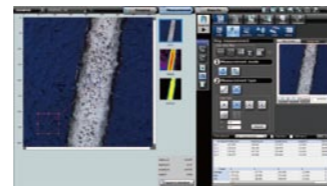

3D Step measurement

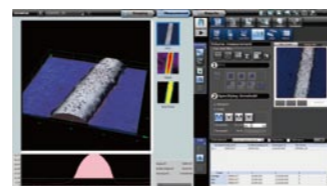

3D Area and Volume measurement

2D and 3D measurements — enable measurement from every angle for various applications

DSX500 scopes show Olympus' dedication to accurate measurement with its telecentric optics and frame design. The measurement capabilities are far and away more accurate than digital microscopes, with much greater reliability. The measurements are accurate and consistently repeatable, the test for reliable accuracy, always.

## Accuracy and Repeatability Guaranteed

The DSX500 provides precise and repeatable measurements. Everything from an objective lens to the frame is manufactured in an Olympus factory under strict inspection criteria. The accuracy is guaranteed under the traceability system connecting to national standard.

\*Calibration by Olympus or dealer specialists necessary



A traceability diagram from a DSX500 series opto-digital microscope

## Auto-Calibration Eliminates Setup Scatter

Proper calibration is basic to precise measurement, and with Olympus DSX500, any operator can calibrate simply and accurately. This eliminates scattering that naturally comes when different operators calibrate, and naturally increases reliability of read-outs. In addition, the system's calibration report shows who did the calibration and when.



\*A special calibration sample is necessary

## Long List of Measurement Items Include Both 2D and 3D Choices

Any DSX500 microscope comes equipped for both 2D and 3D images. That means you can measure along the X,Y axis, or along X, Y, and Z axes. Observe, inspect, or measure from any angle. And the result of inspection can be reported by the same application.

## Low Center of Gravity, Sturdy Frame, and Vibration Compensation Ensure a Steady Observation and Measurement Environment

The low center of gravity and sturdy frame of DSX500 scopes give sufficient stability for inspections at high magnification. Furthermore, vibration compensation absorbs any vibration that might affect inspection or measurement at high magnification and adjusts for any vibration-caused blur in 3D images.

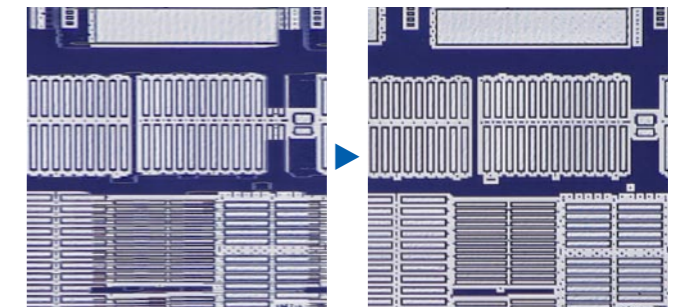

Without compensation

With compensation

## Telecentric Optics Ensure Precise Dimension Measurement

With telecentric optics, the size of the image does not alter with changes in focus position, unlike digital microscopes. What's more, trained staff check every scope upon delivery to ensure accuracy.

## OLYMPUS Stream Can Analyze DSX500's Data

Metallographic evaluation, such as granularity analysis, is done with OLYMPUS Stream, an image-analysis program.



Particle analysis

Cast-iron analysis





# DSX500 Opto-digital Microscope Offers Operating Simplicity and Ultra High-resolution Visuals that Cannot Be Matched by Other Industrial Microscopes or Digital Microscope Systems

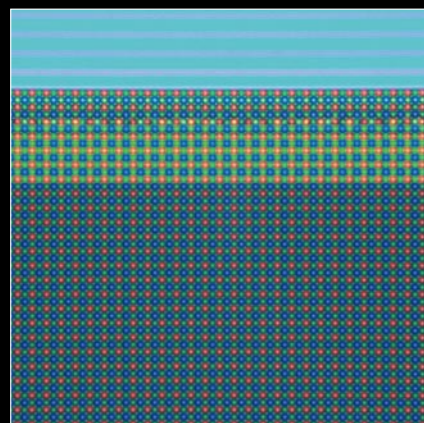

CCD  
(Brightfield)



Particle on semiconductor wafer  
(Darkfield)

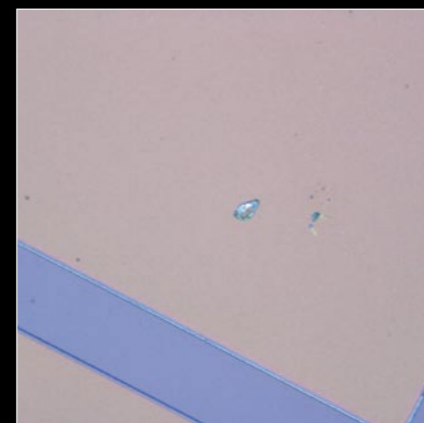

Particle on semiconductor wafer  
(MIX)

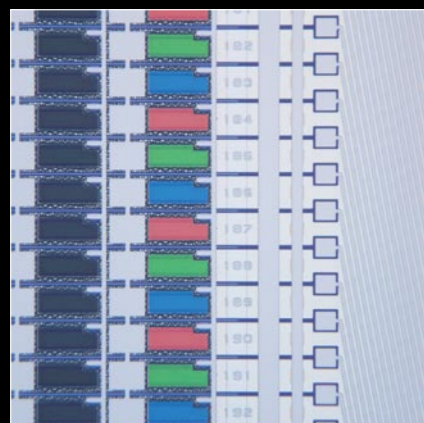

LCD  
(Brightfield, transmitted light illumination)



Coating surface  
(DIC)

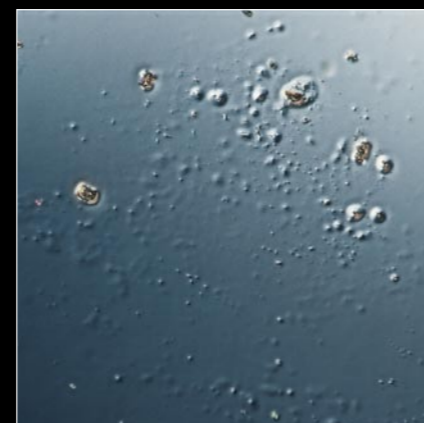

Coating surface  
(DIC+HDR)

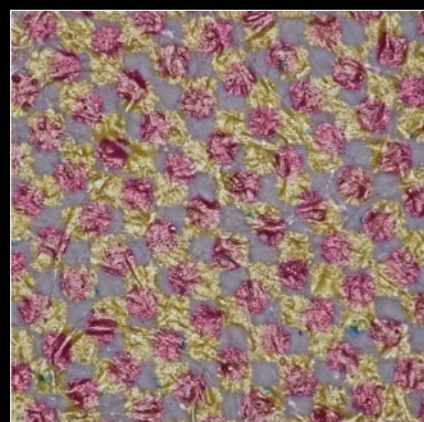

Printing surface  
(Brightfield + HDR)

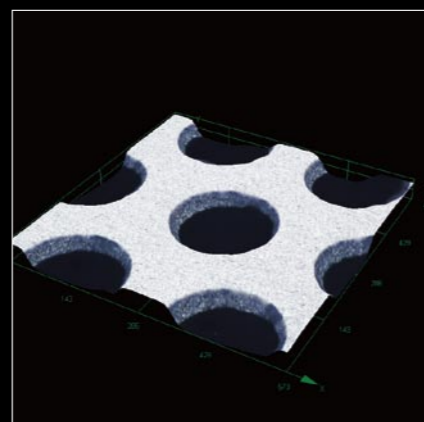

Mold component  
(3D)

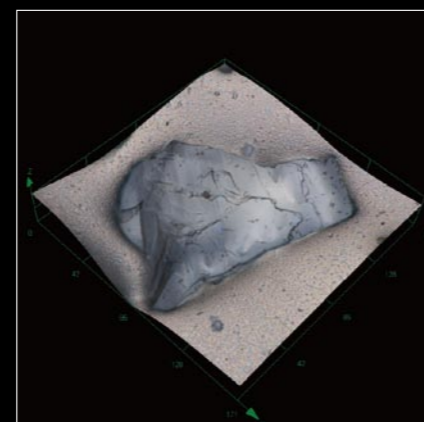

Diamond grindstone  
(3D)

## DSX500 System diagram

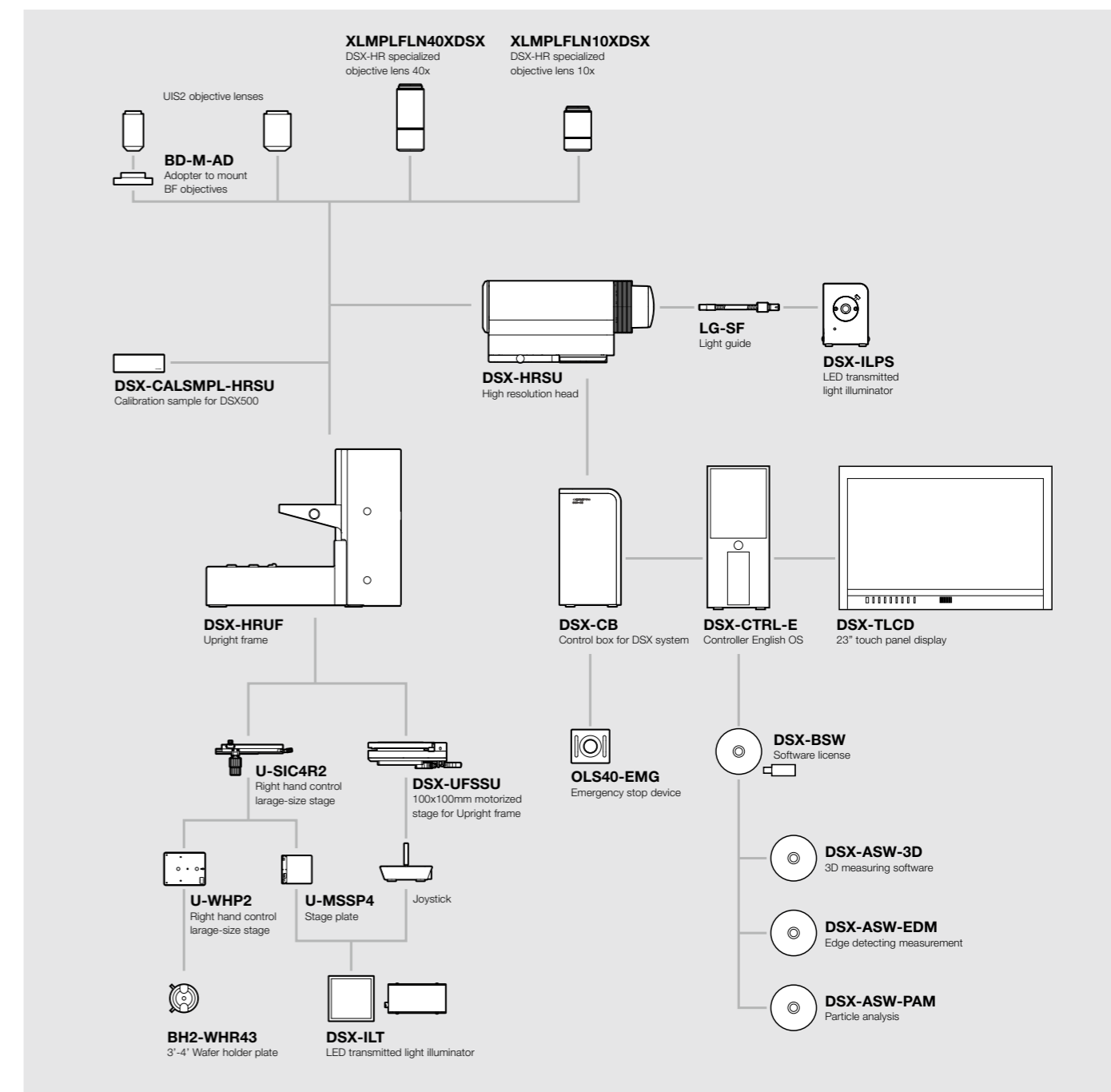

# DSX500 Specifications

Zoom ratio		13.5x optical zoom (0.26x-3.5x), 30x with digital zoom	
No. of objective lens		Max 2 (restriction applies)	
Nosepiece(Manual)	DSX Dedicated objective lens	XL MPLFLN10X, XL MPLFLN40X	
	Mountable objective lens	UIS2 objective lens: MPLFLN1.25X, MPLFLN2.5X, MPLFLN5XBDP, MPLFLN10XBDP, MPLFLN20XBDP, MPLFLN50XBDP, LMPLFLN10XBD, LMPLFLN20X, LMPLFLN50X, MPLAPON50X	
Illumination	Embedded standard	Bright field: LED, Dark field: LED	
	Optional illumination	High intensity LED *1 / Transmitted LED	
Main frame	Image sensor	1/1.8 inch, 2.01 megapixels, Color CCD (Total pixels : 2.10 megapixels) Total pixels : 1688(H) x 1248(V) Available pixels: 1628(H) x 1236(V) Effective pixels : 1600(H) x 1200(V)	
	Cooling method	Peltier colling	
Camera	Scan mode	Progressive scan	
	Frame rate	15fps / 27fps with banning mode	
Image resolution	Normal	: 1194x1194(1:1) / 1592x1194(4:3)	
	Fine	: 1194x1194(1:1) / 1592x1194(4:3)	
Sensitivity	Super fine	: 3594x3594(1:1) / 4792x3594(4:3)	
		ISO100 / 200 / 400 / 800 / 1600 equivalent	
Focusing part	Stroke	95 mm	
	Resolution	0.01 μm	
Maximum specimen height	DSX	65 mm	
	UIS2	95 mm	
Motorized stage	DSX-UFSSU (Motorized)	Stroke	100 x 100 mm
	U-SIC4R (Manual)	Load capacity	3 kg
LCD Monitor	Stroke	100 x 100 mm	
	Load capacity	1 kg	
Weight	Size	23" with Touch panel and Full HD color LCD monitor	
	Resolution	1920(H)x1080(V)	
Weight		Approx. 38.6 kg (Main frame, Motorized stage, LCD Monitor, Control box, PC)	
Input rating		100-120V/220-240V, 185VA, 50/60Hz	

\*1 Cannot be used with the embedded standard LED.

## DSX500 Series Objective Lens

Series	Model	Perforal distance	N.A.	W.D. (mm)	Actual F.O.V. (μm) *3	Total Magnification *4
DSX dedicated objective lens	XL MPLFLN10XDSX *1	75 mm	0.3	30.0	1,960-151	139x-1,803x
	XL MPLFLN40XDSX *1		0.8	4.5	490-38	555x-7,211x
UIS2 objective lens	MPLFLN1.25X *2	45 mm	0.04	3.5	15,684-1,206	17x-225x
	MPLFLN2.5X *2		0.08	10.7	7,842-603	35x-451x
	MPLFLN5XBDP		0.15	12.0	3,921-302	69x-901x
	MPLFLN10XBDP		0.25	6.5	1,960-151	139x-1,803x
	MPLFLN20XBDP		0.4	3.0	980-75	277x-3,606x
	MPLFLN50XBDP		0.75	1.0	392-30	693x-9,014x
	LMPLFLN10XBD		0.25	10.0	1,960-151	139x-1,803x
	LMPLFLN20XBD		0.4	12.0	980-75	277x-3,606x
	LMPLFLN50XBD		0.5	10.6	392-30	693x-9,014x
	MPLAPON50X *1		0.95	0.35	392-30	693x-9,014x

\*1 DF and MIX are not available \*2 Available for BF only \*3 At aspect ratio 1:1 (with factory default value) \*4 At aspect ratio 1:1

## DSX Series

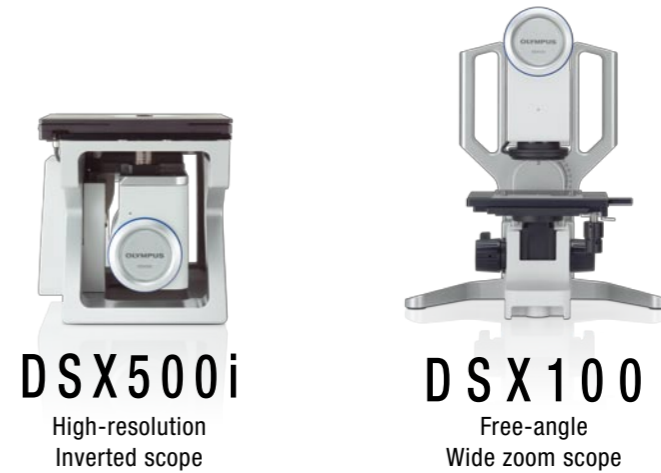

## DSX500 Dimensions

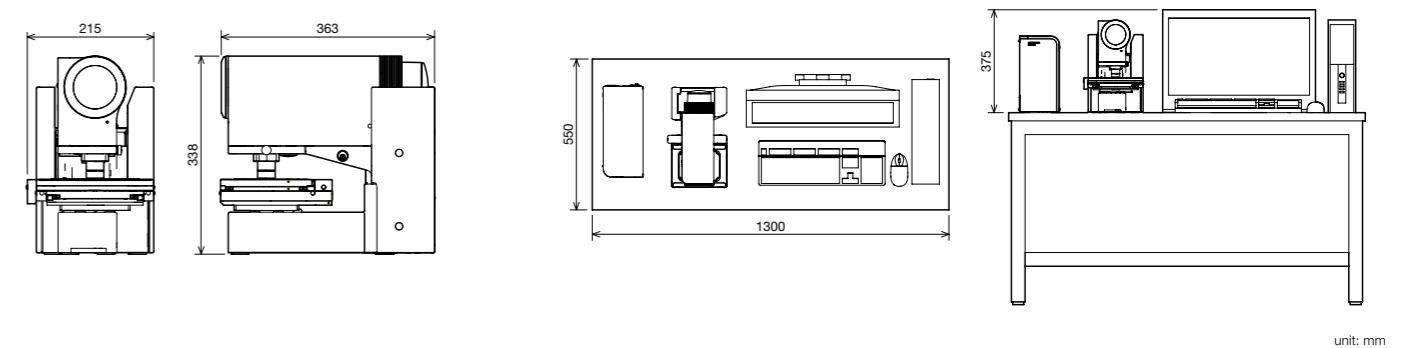

unit: mm

